



19011103 A00

1

Overview

Thank you for purchasing the GL-1600END digital Input expansion module developed by Inovance. This product is a 16-channel digital transistor input module that supports source and sink input.

This guide describes the specifications, characteristics and usage of the product. Read this guide carefully before using to ensure safety. For the latest version of the document, visit our website

Safety Instructions

Safety Precautions

- 1) Before installing, using, and maintaining this product, read the safety information and precautions thoroughly, and comply with them during operations.
- 2) To ensure the safety of humans and products, follow the signs on the product and all the safety instructions in this user guide.
- 3) The "CAUTION", "WARNING" and "DANGER" signs are only supplements to the safety instructions.
- 4) Use this product according to the designated environment requirements. Damage caused by improper usage is not covered by warranty.
- 5) Inovance shall take no responsibility for any personal injuries or property damage caused by improper usage.

Safety Levels and Definitions

- WARNING** Indicates that failure to comply with the notice may result in severe personal injuries or even death.
- CAUTION** indicates that failure to comply with the notice may result in minor or moderate personal injury or damage to the equipment.

Please keep this guide well so that it can be read when necessary and forward this guide to the end user.

During control system design

- WARNING**
 - ◆ Provide a safety circuit outside the PLC so that the control system can still work safely once external power failure or PLC fault occurs.
 - ◆ Add a fuse or circuit breaker because the module may smoke or catch fire due to long-time overcurrent caused by operation above rated current or load short-circuit.
- CAUTION**
 - ◆ An emergency stop circuit, a protection circuit, a forward/reverse operation interlocked circuit, and a upper position limit and lower position limit interlocked circuit must be set in the external circuits of PLC to prevent damage to the machine.
 - ◆ To ensure safe operation, for the output signals that may cause critical accidents, please design external protection circuit and safety mechanism;
 - ◆ Once PLC CPU detects abnormality in the system, all outputs may be closed; however, when a fault occurs in the controller circuit, the output may not be under control. Therefore, it is necessary to design an appropriate external control circuit to ensure normal operation;
 - ◆ If the PLC's output units such as relays or transistors are damaged, the output may fail to switch between ON and OFF states according to the commands;
 - ◆ The PLC is designed to be used in indoor electrical environment (overvoltage category II). The power supply must have a system-level lightning protection device, assuring that overvoltage due to lightning shock can't be applied to the PLC's power supply input terminals, signal input terminals and output terminals and so forth, so as to avoid damage to the equipment.

2

During installation

- WARNING**
 - ◆ Installation must be carried out by the specialists who have received the necessary electrical training and understood enough electrical knowledge.
 - ◆ Disconnect all external power supplies of the system before removing/installing the module. Failure to do so may result in electric shock, module fault or malfunction.
 - ◆ Do not use the PLC where there are dust, oil smoke, conductive dust, corrosive or combustible gases, or exposed to high temperature, condensation, wind & rain, or subject to vibration and impact. Electric shock, fire and malfunction may also result in damage or deterioration to the product.
 - ◆ The PLC is open-type equipment that must be installed in a control cabinet with lock (cabinet housing protection >IP20). Only the personnel who have received the necessary electrical training and understood enough electrical knowledge can open the cabinet.
- CAUTION**
 - ◆ Prevent metal filings and wire ends from dropping into ventilation holes of the PLC during installation. Failure to comply may result in fire, fault and malfunction.
 - ◆ Ensure there are no foreign matters on ventilation surface. Failure to comply may result in poor ventilation, which may cause fire, fault and malfunction.
 - ◆ Ensure the module is connected to the respective connector securely and hook the module firmly. Improper installation may result in malfunction, fault or fall-off.

During wiring

- WARNING**
 - ◆ Wiring must be carried out by personnel who have received the necessary electrical training and understood enough electrical knowledge.
 - ◆ Disconnect all external power supplies of the system before wiring. Failure to comply may result in electric shock, equipment fault or malfunction.
 - ◆ Install the terminal cover attached to the product before power-on or operation after wiring is completed. Failure to comply may result in electric shock.
 - ◆ Perform good insulation on terminals so that insulation distance between cables will not reduce after cables are connected to terminals. Failure to comply may result in electric shock or damage to the equipment.
- CAUTION**
 - ◆ Prevent dropping metal filings and wire ends drop into ventilation holes of the PLC at wiring. Failure to comply may result in fire, fault and malfunction.
 - ◆ The external wiring specification and installation method must comply with local regulations. For details, see the wiring section in this guide.
 - ◆ To ensure safety of equipment and operator, use cables with sufficient diameter and connect the cables to ground reliably.
 - ◆ When connecting the cable, ensure that you have recognized the connector type correctly. Failure to comply may result in module and external equipment fault.
 - ◆ Tighten bolts on the terminal block in the specified torque range. If the terminal is not tight, short-circuit, fire or malfunction may be caused. If the terminal is too tight, fall-off, short-circuit, fire or malfunction may be caused.
 - ◆ If the connector is used to connect with external equipment, perform correct crimping or welding with the tool specified by manufacturer. If connection is in poor contact, short-circuit, fire or malfunction may be caused.
 - ◆ A label on the top of the module is to prevent foreign matters entering the module. Do not remove the label during wiring. Remember to remove it before system operation, facilitating ventilation.
 - ◆ Do not bundle control wires, communication wires and power cables together. They must be run with distance of more than 100 mm. Otherwise, noise may result in malfunction.
 - ◆ Select shielded cables for high-frequency signal input/output in applications with serious interference so as to enhance system anti-interference ability.

During maintenance & inspection

- WARNING**
 - ◆ Maintenance & inspection must be carried out by personnel who have the necessary electrical training and experience.
 - ◆ Do not touch the terminals while the power is on. Failure to comply may result in electric shock or malfunction.
 - ◆ Disconnect all external power supplies of the system before cleaning the module or re-tightening screws on the terminal block or screws of the connector. Failure to comply may result in electric shock.
 - ◆ Disconnect all external power supplies of the system before removing the module or connecting/removing the communication wirings. Failure to comply may result in electric shock or malfunction.
- CAUTION**
 - ◆ Read the guide carefully and ensure safety before online modification, forcible output, and RUN/STOP operation.
 - ◆ Disconnect the power supply before installing/removing the extension card.

At disposal

- CAUTION**
 - ◆ Treat scrapped module as industrial waste. Dispose the battery according to local laws and regulations.

3

Product Information

Model and Nameplate

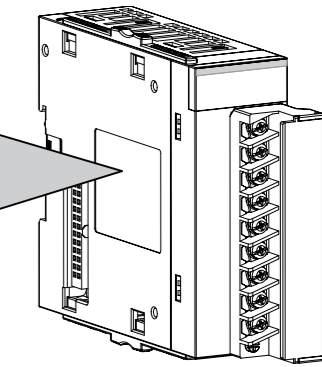
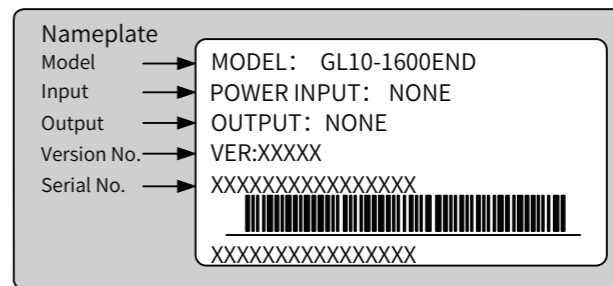
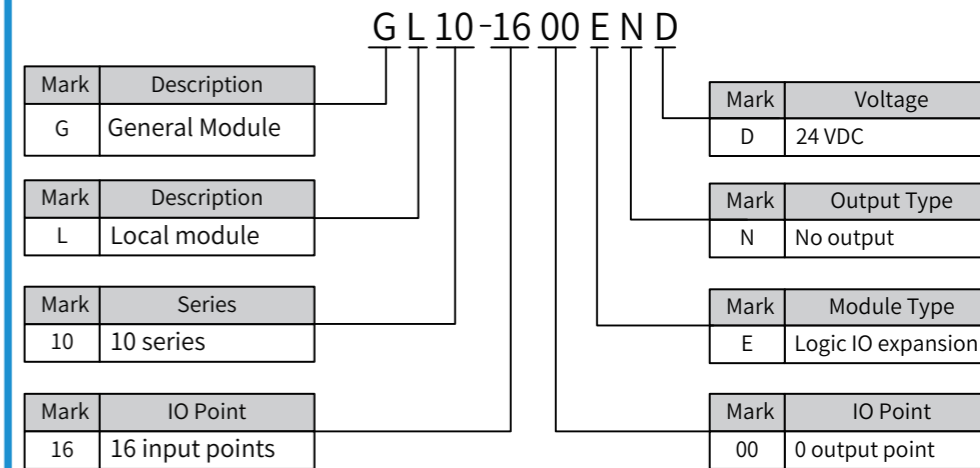

Figure 1 Description of model and nameplate

Model	Classification	Description
GL10-1600END	Digital input module	16-point DI module; 24 VDC input

External Interface

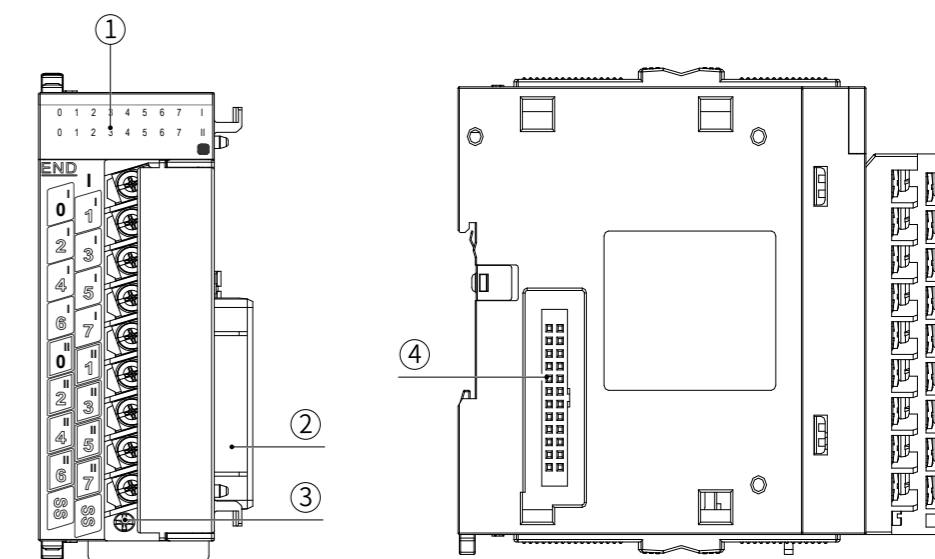

Figure 2 Module connectors

No.	Name	Function
①	Signal indicators	Corresponding to various input signals ON: input active OFF: input inactive
②	Local expansion module back-end interface	Connect back-end module, not supporting hot plugging
③	User input terminal	8-channel inputs x 2
④	Local expansion module front-end interface	Connect front-end module, not supporting hot plugging

General Specifications

Item	Specifications
Input channels	16
Input connection method	18-point wiring terminal
Input type	Digital input
Input mode	SINK/SOURCE
Input voltage class	24 VDC (max.: 30 V)
Internal 5 V power consumption	55 mA (typical)
Input current (typical)	5.3 mA
ON voltage	> 15 VDC
OFF voltage	< 5 VDC
Port filter time	10 ms
Input resistance	4.3 kΩ
Input signal form	DC voltage input, supporting SINK/SOURCE input
Isolation method	Opto-couplers isolation
Input action display	Input indicator ON when the input is in the driving state

Mechanical Design

Mounting Dimensions

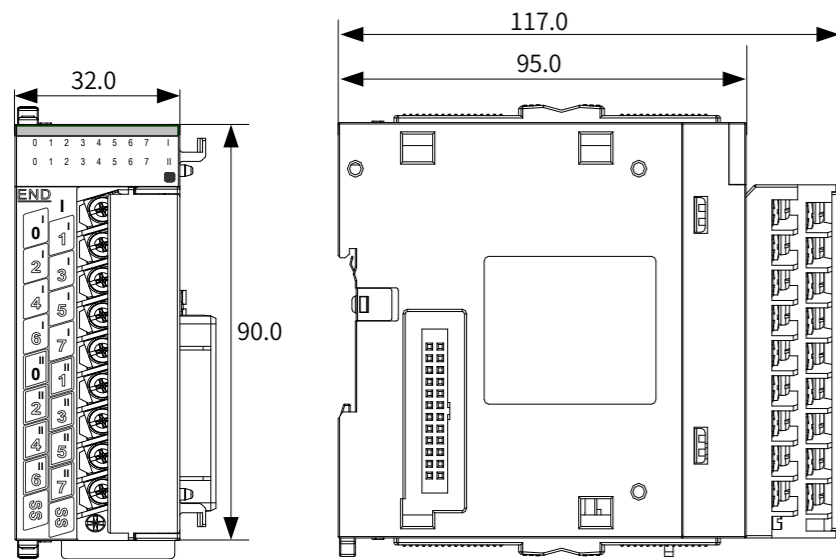

Figure 3 Mounting dimensions (in mm)

Electrical Design

Cable Selection

Cable Name	Model	Applicable Cable Diameter		Manufacturer	Crimping Tool
		Chinese Standard/mm ²	American Standard/AWG		
Y-type cable lug	TNS1.25-3	0.5-0.75	22-18	Suzhou Yuanli	RYO-8 YYT-8

Those cable lugs are applicable to digital/analog modules, and the cable rated temperature is required to be above 75°C.

Cable Preparing

Cable preparing procedures:

- 1) Strip back the wire outer coating by 6 mm.
- 2) Pass the cable through the tube of proper wire size.
- 3) Insert the exposed end into the hole of the cable lug, and then crimp it with recommended crimping tool.
- 4) Use a heat-shrinkable tube (Φ3) of 20 mm long to wrap the copper tube of a cable lug and then perform thermal shrinkage.

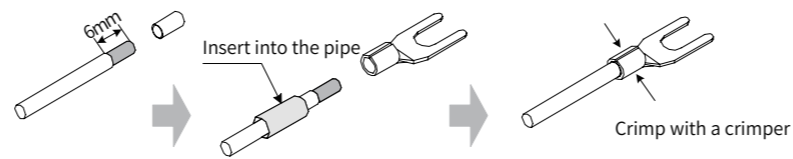

Figure 4 Diagram of cable preparing

- 5) Put the cable lug onto the terminal and tighten the screw with a screwdriver. The maximum tightening torque is 0.8 N·m.

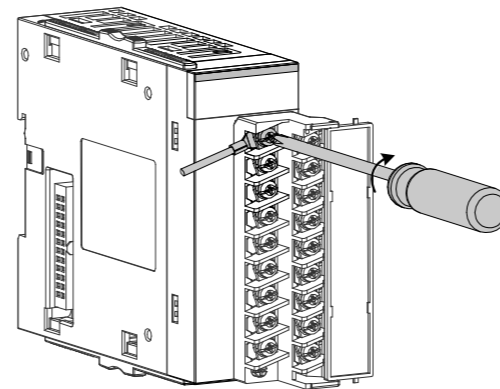

Figure 5 Connecting cable to terminal block

Terminal Layout

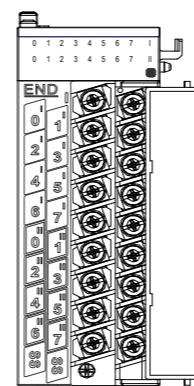

Figure 6 Terminal layout of the module

Terminal Description

SN	Network Name	Type	Function	Remarks
The 1st Group of Input Interfaces				
1	I0	Input	The 1st group of user input 0	SINK/SOURCE input
2	I1	Input	The 1st group of user input 1	SINK/SOURCE input
3	I2	Input	The 1st group of user input 2	SINK/SOURCE input
4	I3	Input	The 1st group of user input 3	SINK/SOURCE input
5	I4	Input	The 1st group of user input 4	SINK/SOURCE input
6	I5	Input	The 1st group of user input 5	SINK/SOURCE input
7	I6	Input	The 1st group of user input 6	SINK/SOURCE input
8	I7	Input	The 1st group of user input 7	SINK/SOURCE input
The 2nd Group of Input Interfaces				
9	I0	Input	The 2nd group of user input 0	SINK/SOURCE input
10	I1	Input	The 2nd group of user input 1	SINK/SOURCE input
11	I2	Input	The 2nd group of user input 2	SINK/SOURCE input
12	I3	Input	The 2nd group of user input 3	SINK/SOURCE input
13	I4	Input	The 2nd group of user input 4	SINK/SOURCE input
14	I5	Input	The 2nd group of user input 5	SINK/SOURCE input
15	I6	Input	The 2nd group of user input 6	SINK/SOURCE input
16	I7	Input	The 2nd group of user input 7	SINK/SOURCE input

SN	Network Name	Type	Function	Remarks
Common				
17	SS	Power	Common	-
18	SS	Power	Common	-

External Wiring

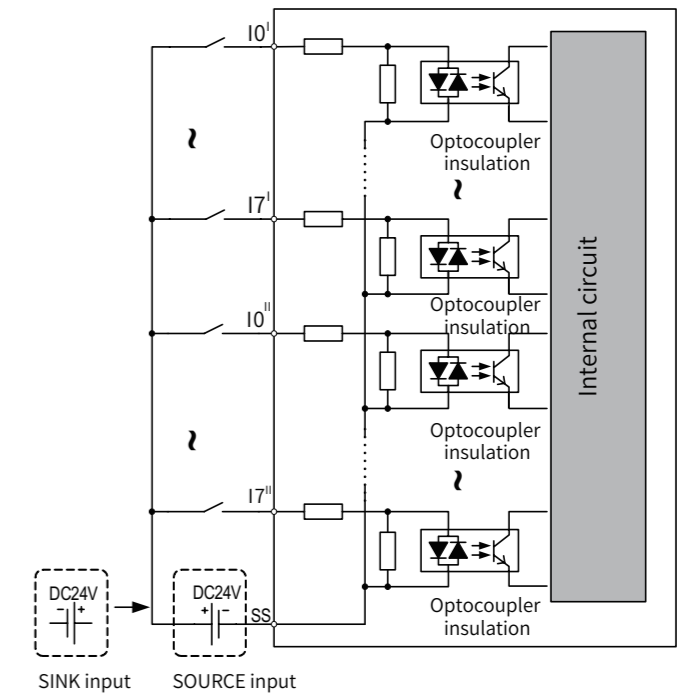

Figure 7 Module wiring diagram

Wiring precautions

- ◆ Do not bundle the terminal connection cables together with power cables (high voltage, large current) which produce strong interference signals. Separate it from other cables and avoid cabling in parallel.
- ◆ Select recommended cables and adapter boards for connection. It is recommended that shielded cables be used as terminal connection cables to enhance capacity of resisting interference.

Pobrano z: <https://sterowniki-plc.net/modul-16-wejsc-cyfrowych-gl10-1600end-int-inovance>